

STEEL DOOR INSTALLATION GUIDE

CAUTIONING

The installation of a steel door should be done by a qualified professional and must comply with the standard. Improper installation could cause a malfunction of the door, premature wear and risk of water/air infiltration. Evidently, to honor the guarantees, the doors must be installed level, square and plumb.

PREPARATION OF THE OPENING

Sufficient space should be left around the door, to allow deflections and movements due to thermal and mechanical stresses that the door will have to undergo.

SHIMMING

The shim blocks, squareness and positioning shall be sufficient to minimize deflection and distortion of the frame and to allow proper operation of the door. For shim positioning and other information please refer to building code A-440.4-07.

To allow expansion **NEVER** place a shim in the top section of the frame. (header)
The shims used must fit snugly within the space without deforming the frame, otherwise the door frame may be stretched at the time of anchoring. First, anchor the jamb on the hinge side and make sure that the anchors cross the shims positioned under the hinges. Then, anchor the bore jamb side while keeping an equal distance between the door and the header.

At least one countersunk screw per hinge or per side must penetrate the structure (opening structure) by at least 38mm (1-1/2"). (See Figure #1)

*The use of 3-1/2" #8 screws is recommended.

☒ = Shim

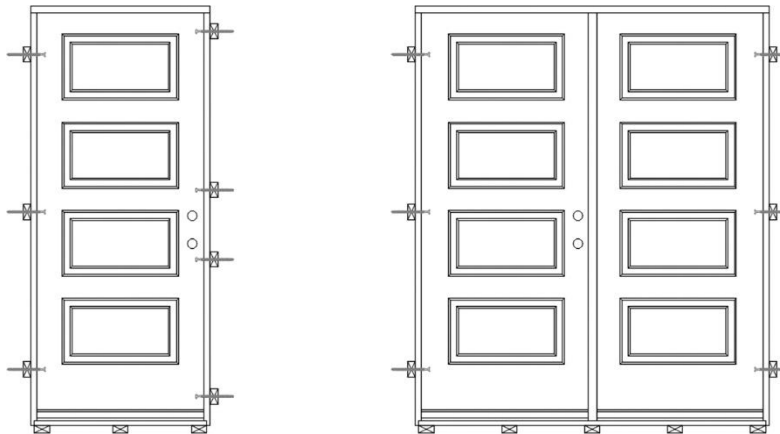
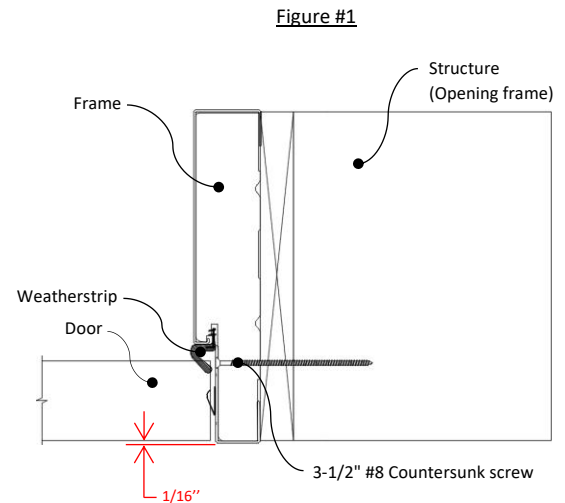

INSTALLATION FEATURES

The door must be level, square and plumb so as to not affect the integrity and function of the product. These adjustments should be made when positioning the frame in the opening and before finalizing the anchors. (See figure #2)

The door will be considered :

- **Leveled** when the threshold is level and the vertical curvatures are less than 2mm. (1/16").
- **Squared** when the difference between the 2 diagonals is less than 4mm. (1/8")
- **Plumbed** when the misalignment of the head in relation to the threshold is less than 2mm (1/16") and that the misalignment of the frame is small enough not to compromise the proper functioning of the door.
- **Sealed** when the door is compressed 1/16" from the frame. Check the compression when the door is closed. (See figure #1)

To adjust the door frame, adjust with the door half-open perfectly parallel to the frame. (See figure #3)

STEEL DOOR INSTALLATION GUIDE

Figure #2

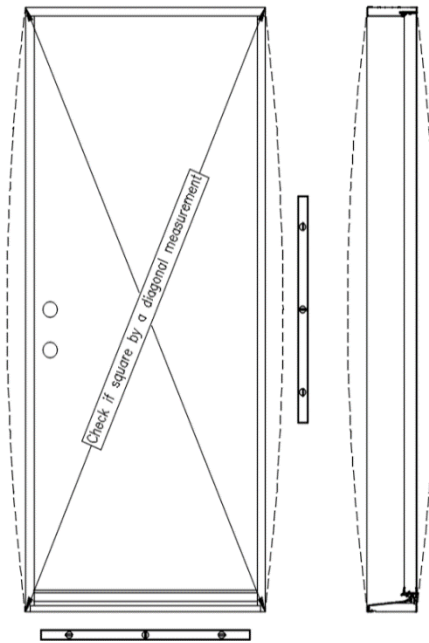
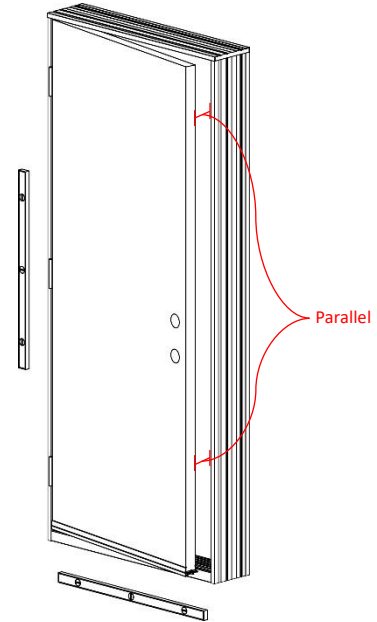

Figure #3



INSULATION

The Insulator must fill the entire cavity between the opening and the frame. (See figure #4)

Mineral wool insulation : Pull apart the mineral wool before inserting it to avoid having to force it during installation. Using a piece of cedar shingle, fill the cavity taking care not to compress the wool, otherwise the wool loses its insulating efficiency and can exert pressure on the frame. Proceed in consecutive layers until the cavity is full. It is very important to ensure the continuity of the insulation.

Polyurethane foam spray insulation : The low-expansion polyurethane foam is still very effective in filling holes and providing air tightness. However, it must be applied in 2 layers with a waiting time of a few minutes between each layer to prevent it from exerting pressure on the frame. Please ensure that the product remains compressed at all times.

Figure #4

